

CE-300 SERIES OPERATING INSTRUCTIONS

INPUT RATING: 100-240VAC, 6 A, 50-60 Hz.

OUTPUT RATING: 300 Watts maximum.

MODEL LISTING:

Model	Output 1	Output 2	Output 3	Output 4	Output 5
CE-300-5001	+5VDC/40A	+24VDC/4A(6Apk)	+12VDC/6A	-5VDC/1A	-12VDC/2A
CE-300-5002	+5VDC/40A	+12VDC/8A(12Apk)	-12VDC/6A	-5VDC/1A	+24VDC/2A
CE-300-5003	+5VDC/40A	+12VDC/8A(12Apk)	+24VDC/3A	-15VDC/1A	+15VDC/2A
CE-300-5004	+5VDC/40A	+24VDC/4A(6Apk)	24VDC/3A	-12VDC/1A	+12VDC/1A
CE-300-5005	+24VDC/8A	+12VDC/8A(12Apk)	+5VDC/6A	-15VDC/1A	+15VDC/2A
CE-300-5006	+24VDC/8A	24VDC/4A(6Apk)	+5VDC/6A	-15VDC/1A	+15VDC/2A
CE-300-5007	+5VDC/40A	+12VDC/8A(12Apk)	-12VDC/6A	5VDC/1A	5VDC/2A
CE-300-5008	+24VDC/8A	+5VDC/8A	+12VDC/6A	-5VDC/1A	-12VDC/2A
CE-300-5009	+5VDC/40A	+12VDC/8A(12Apk)	-12VDC/6A	-5VDC/1A	+12VDC/2A
CE-300-5010	-15VDC/13A	+3.3VDC/12A	-12VDC/6A	-5.2VDC/1A	-12VDC/2A
CE-300-5011	+5VDC/45A	+12VDC/8A(12Apk)	12VDC/6A	18VDC/1A	12VDC/2A
CE-300-5012	+5VDC/40A	+28VDC/3A(5Apk)	+12VDC/6A	-5VDC/1A	-12VDC/2A
CE-300-5013	+5VDC/40A	+3.3VDC/12A	+24VDC/4A	-5VDC/1A	12VDC/2A
CE-300-5014	5VDC/40A	8VDC/6A	15VDC/3A	18VDC/1A	15VDC/2A
CE-300-4001	+5VDC/40A	+12VDC/8A(12Apk)	-5VDC/5A	----	-12VDC/2A
CE-300-4002	+5VDC/40A	+24VDC/4A(6Apk)	+12VDC/6A	----	-12VDC/2A
CE-300-4003	+5VDC/40A	+24VDC/4A(6Apk)	+15VDC/4A	----	-15VDC/2A
CE-300-4004	+24VDC/8A	+12VDC/8A(12Apk)	+5VDC/6A	----	-12VDC/2A
CE-300-4005	+5VDC/40A	-5.2VDC/12A	+12VDC/6A	----	-12VDC/2A
CE-300-4006	+24VDC/8A	+12VDC/8A(12Apk)	----	-12VDC/1.5A	5VDC/2A
CE-300-4007	+24VDC/8A	+15VDC/6A(8Apk)	+5VDC/6A	----	-15VDC/2A
CE-300-4008	+5VDC/40A	+12VDC/8A(12Apk)	+15VDC/4A	----	-15VDC/2A
CE-300-4009	+24VDC/8A	+12VDC/8A(12Apk)	+5VDC/10A	----	-12VDC/2A
CE-300-4011	+5VDC/40A	+3.3VDC/12A	----	+12VDC/2A	-12VDC/2A
CE-300-3001	+5VDC/40A	+12VDC/8A(12Apk)	-12VDC/6A	----	----
CE-300-3002	+5VDC/40A	+12VDC/8A(12Apk)	+24VDC/3A	----	----
CE-300-3003	+5VDC/40A	+15VDC/6A(8Apk)	-15VDC/4A	----	----
CE-300-3004	+12VDC/16A	-12VDC/8A(12Apk)	+5VDC/6A	----	----
CE-300-3005	+5VDC/40A	+3.3VDC/12A	+12VDC/6A	----	----
CE-300-3006	+5VDC/40A	+3.3VDC/12A	----	+12VDC/2A	----
CE-300-2001	+5VDC/40A	+24VDC/4A(6Apk)	----	----	----
CE-300-2002	+12VDC/16A	-12VDC/8A(12Apk)	----	----	----
CE-300-2003	+15VDC/13A	-15VDC/6A(10Apk)	----	----	----
CE-300-2004	+24VDC/8A	-24VDC/4A(6Apk)	----	----	----
CE-300-2005	+24VDC/12A	----	----	----	+5VDC/2A
CE-300-1001	5VDC/60A	----	----	----	----
CE-300-1002	12VDC/25A	----	----	----	----
CE-300-1003	15VDC/20A	----	----	----	----
CE-300-1004	24VDC/12A	----	----	----	----
CE-300-1005	20VDC/15A	----	----	----	----

NOTES: 1. A suffix may be added to the model number to indicate the following optional configurations:
(OVP-over voltage protection, PF-power fail).



DECLARATION OF CONFORMITY

12

Manufacturer: Integrated Power Designs, Inc.
Manufacturer's Address: 300 Stewart Road, Wilkes-Barre, PA 18706 USA

Declare that all models listed above including all options are in conformity with the applicable requirements of:

EN 60950-1/A1:2010 Information Technology Equipment. General Requirements

following the provisions of the Low Voltage Directive:

2006/95/EC of 12 December 2006.

In addition, all models are Certified to be in compliance with applicable requirements of UL 60950-1 2nd Edition, IEC 60950-1/A1:2009 including all EU national deviations, CAN/CSA-C22.2 No. 60950-1-07 and EN 60950-1/A1:2010.

BY: Steven Thompson- President
Steven Thompson

PLACE: Integrated Power Designs
300 Stewart Road, Wilkes-Barre, PA 18706 USA

DATE: January 2, 2012

EUROPEAN CONTACT:
CompuMess Elektronik GmbH
Lise-Meitner-Strasse 1
85716 Unterschleißheim
Telephone: (089) 32 15 01-0

CE-300 SERIES OPERATING INSTRUCTIONS

- WARNING! RISK OF FIRE!** An open internal fuse indicates a catastrophic failure of circuit component(s). Repair must be by authorized IPD personnel only. Refer to fuse rating on power supply circuit board for rating.
- WARNING! SHOCK HAZARD!** Dangerous voltages are present on some components, printed circuit board traces and heatsinks.
- INPUT FUSE:** This product includes a single fuse in the phase lead only. In consideration of IEC 60601-1/A2:1995 Clause 57.6, a second fuse may be required in the neutral lead of the end use equipment
- GROUNDING:** The protective earth (ground) terminal must be bonded to protective earth in the end use equipment.
- ISOLATION:** Primary to secondary creepage distance is 6.3 mm minimum. Primary to ground creepage distance is 2.5 mm minimum. Secondary to ground creepage is not specified. The required creepage distances from primary to secondary and primary to ground must be maintained in the end use equipment to preserve the required safety spacings.
- OUTPUTS:** All outputs are SELV under normal and single fault conditions
- TEMPERATURES:** The maximum operating temperatures of safety components as defined in the applicable safety standards must not be exceeded after installation in the end use equipment. Output power, ambient air temperature and convection or forced air cooling availability should be considered in the end use equipment.
- HIPOT:** In consideration of UL 60950-1 2nd Edition Clause 5.2.2, care must be taken to insure the voltage applied to a reinforced insulation does not overstress basic insulation. Breakdown of basic insulation and catastrophic failure of the power supply may result if a test voltage of greater than 1500 VAC/2121VDC is applied between primary and secondary circuits. Each isolating component is factory tested at 3000 VAC minimum prior to installation.
- INSTALLATION:** The power supplies included in model listing on reverse side are considered components intended for professional installation into end use equipment.
- EMISSIONS:** This product was tested for compliance with EN 55022 and EN 55011 Class B conducted and radiated emissions using the techniques listed below and non-inductive load resistors to simulate operation in a typical installation. All or a combination of the following requirements may be necessary to insure compliance in the end use equipment.
1. Installation of the power supply, output cables and loads in a shielded enclosure.
 2. Use of shielded I/O cables.
 3. Use of ferrite beads on I/O cables.
 4. Grounded output returns as specified under GROUNDING above.

CONNECTIONS / DIMENSIONS:

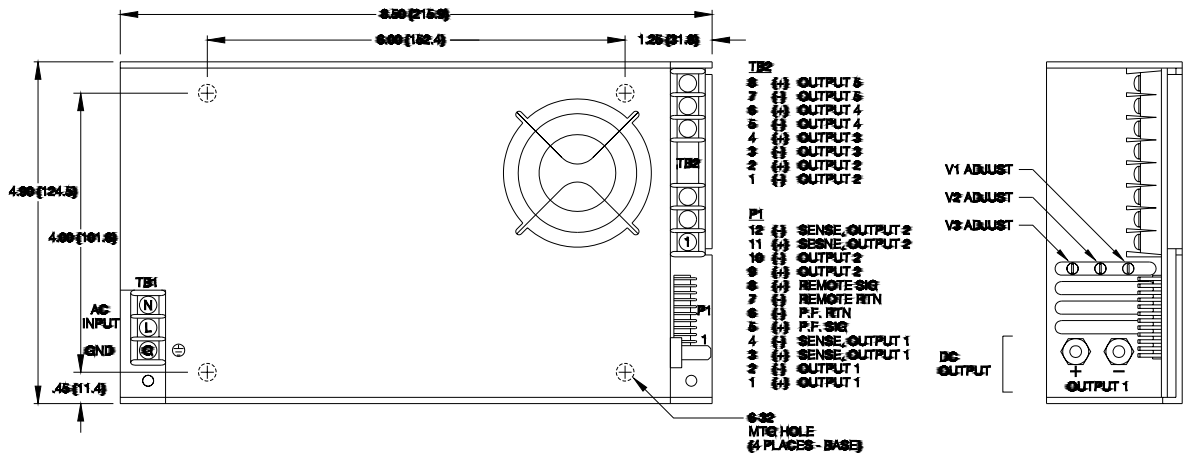

- CONNECTORS:**
- TB1/G: AC Input - Terminal block with 6-32 screws on 0.325 centers mates with #6, 0.26 inch-wide spade terminals. (10 in.-lb. max.)
- TB2: DC Output - Terminal block with 6-32 screws on 0.325 centers mates with #6, 0.26 inch-wide spade terminals. (10 in.-lb. max.)
- +/-: DC Output - 10-32 threaded studs mate with #10 ring-tongue terminals.
- P1: Option/Sense - .100 breakaway header mates with Molex 22-01-2127 or equivalent crimp terminal housing with Molex 6459 or equivalent crimp terminal.